

FEATURES

- 1). Improved glass passivation for high reliability and exceptional stability at high temperature
- 2). High di/dt and dv/dt capabilities
- 3). Standard package
- 4). Low thermal resistance
- 5). Metric threads version available
- 6). Types up to 1600V V_{DRM}/V_{RRM}

TYPICAL APPLICATIONS

- 1). Medium power switching
- 2). Phase control applications
- 3). Can be supplied to meet stringent military, aerospace and other high-reliability requirements

MAJOR RATINGS AND CHARACTERISTICS

Parameters		K25RIA		Unit
		10 to 120	140 to 160	
$I_{F(AV)}$		25	25	A
	@ T_C	85	85	°C
$I_{F(RMS)}$		40	40	A
I_{FSM}	@ 50Hz	420	398	A
	@ 60Hz	440	415	A
I^2t	@ 50Hz	867	795	A ² s
	@ 60Hz	790	725	A ² s
V_{DRM}/V_{RRM}		100 to 1200	1400 to 1600	V
T_q	typical	110		μs
T_J		- 65 to 125		°C

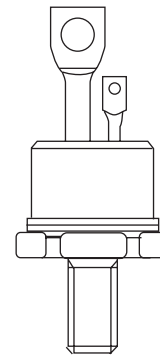

ELECTRICAL SPECIFICATIONS

1). Voltage Ratings

Type number	Voltage Code	V_{DRM}/V_{RRM} , maximum repetitive peak reverse voltage *(1)	V_{RSM} , maximum non-repetitive peak reverse voltage *(2)	I_{DRM}/I_{RRM} max. @ $T_J = T_{J\ max}$
		V	V	mA
K25RIA	10	100	150	20
	20	200	300	10
	40	400	500	
	60	600	700	
	80	800	900	
	100	1000	1100	
	120	1200	1300	
	140	1400	1500	
	160	1600	1700	

*(1) Units may be broken over non-repetitively in the off-state direction without damage, if di/dt does not exceed 20A/μs

*(2) For voltage pulses with $t_p \leq 5ms$

2). Forward Conduction

Parameters		K25RIA		Unit	Conditions		
		10 to 120	140 to 160				
$I_{T(AV)}$	Max. average forward current	25	25	A	180° conduction, half sine wave		
	@ Case temperature	85	85	°C			
$I_{T(RMS)}$	Max. RMS forward current	40	40	A			
I_{TSM}	Max. peak, one-cycle forward, non-repetitive surge current	420	398	A	t = 10ms	No voltage	Sinusoidal half wave, Initial $T_J = T_J \text{ max.}$
		440	415		t = 8.3ms	reapplied	
		350	335		t = 10ms	100% V_{RRM}	
		370	350		t = 8.3ms	reapplied	
I^2t	Maximum I^2t for fusing	867	795	A^2s	t = 10ms	No voltage	
		790	725		t = 8.3ms	reapplied	
		615	560		t = 10ms	100% V_{RRM}	
		560	510		t = 8.3ms	reapplied	
$I^2\sqrt{t}$	Maximum $I^2\sqrt{t}$ for fusing	8670	7950	$A^2\sqrt{s}$	t = 0.1 to 10ms, no voltage reapplied		
$V_{T(TO)1}$	Low level value of threshold voltage	0.99	0.99	V	$(16.7\% \times \pi \times I_{F(AV)} < I < \pi \times I_{F(AV)})$, $T_J = T_J \text{ max.}$		
$V_{T(TO)2}$	High level value of threshold voltage	1.40	1.15	V	$(I > \pi \times I_{F(AV)})$, $T_J = T_J \text{ max.}$		
r_{T1}	Low level value of forward slope resistance	10.1	11.73	$m\Omega$	$(16.7\% \times \pi \times I_{F(AV)} < I < \pi \times I_{F(AV)})$, $T_J = T_J \text{ max.}$		
r_{T2}	High level value of forward slope resistance	5.7	10.05	$m\Omega$	$(I > \pi \times I_{F(AV)})$, $T_J = T_J \text{ max.}$		
V_{TM}	Max. forward voltage drop	1.71	-	V	$I_{pk} = 50A$, $T_J = 25^\circ C$, $t_p = 10ms$ sine pulse		
		-	180				
I_H	Maximum holding current	130		mA	$T_J = 25^\circ C$, anode supply 12V resistive load		
I_L	Typical latching current	200					
di/dt	Max. rate of rise of turned-on current			A/ μs	$T_J = T_J \text{ max.}$, $V_{DM} = \text{rated } V_{DRM}$ Gate pulse = 20V, 15 Ω , $t_p = 6 \mu s$, $t_r = 0.1 \mu s \text{ max.}$, $I_{TM} = (2x \text{ rated } di/dt) A$		
	VDRM ≤ 600V	200					
	VDRM ≤ 800V	180					
	VDRM ≤ 1000V	160					
	VDRM ≤ 1600V	150					
t_{gt}	Typical turn-on time	0.9		μs	$T_J = 25^\circ C$, at = rated V_{DRM}/V_{RRM} , $T_J = 125^\circ C$		
t_{rr}	Typical reverse recovery time	4			$T_J = T_J \text{ max.}$, $I_{TM} = I_{T(AV)}$, $t_p > 200 \mu s$, $di/dt = -10A/\mu s$		
t_q	Typical turn-off time	110			$T_J = T_J \text{ max.}$, $I_{TM} = I_{T(AV)}$, $t_p > 200 \mu s$, $V_R = 100V$, $di/dt = -10A/\mu s$, $dv/dt = 20V/\mu s$ linear to 67% V_{DRM} , gate bias 0V-100W		
dv/dt	Max. critical rate of rise of	100		V/ μs	$T_J = T_J \text{ max.}$ linear to 100% rated V_{DRM}		
	off-state voltage	300 (*)			$T_J = T_J \text{ max.}$ linear to 67% rated V_{DRM}		

(*) $t_q = 10 \mu s$ sup to 600V, $t_q = 30 \mu s$ up to 1600V available on special request.

(**) Available with: $dv/dt = 1000V/\mu s$, to complete code add S90 i.e. K25RIA120S90.

3). Triggering

Parameters		K25RIA		Unit	Conditions	
P_{GM}	Maximum peak gate power	8.0		W	$T_J = T_J \text{ max.}$	
$P_{G(AV)}$	Maximum average gate power	2.0				
I_{GM}	Max. peak positive gate current	1.5		A	$T_J = T_J \text{ max.}$	
$-V_{GM}$	Maximum peak negative gate voltage	10		V	$T_J = T_J \text{ max.}$	
I_{GT}	DC gate current required to trigger	90		mA	$T_J = -65^\circ\text{C}$ $T_J = 25^\circ\text{C}$ $T_J = 125^\circ\text{C}$ Max. required gate trigger current/voltage are the lowest value which will trigger all units 6V anode-to-cathode applied	
		60				
		35				
V_{GT}	DC gate voltage required to trigger	3.0		V	$T_J = -65^\circ\text{C}$ $T_J = 25^\circ\text{C}$ $T_J = 125^\circ\text{C}$	
		2.0				
		1.0				
I_{GD}	DC gate current not to trigger	2.0		mA	$T_J = T_J \text{ max.}, V_{DRM} = \text{rated value}$	
V_{GD}	DC gate voltage not to trigger	0.2		V	$T_J = T_J \text{ max.}$ $V_{DRM} = \text{rated value}$ Max. gate current/ voltage not to trigger is the max. value which. will not trigger any unit with rated V_{DRM} anode-to-cathode applied	
T_J	Max. operating temperature range	- 65 to 125		$^\circ\text{C}$		
T_{stg}	Max. storage temperature range	- 65 to 125		$^\circ\text{C}$		
R_{thJC}	Max. thermal resistance, junction to case	0.75		K/W	DC operation	
R_{thCS}	Max. thermal resistance, case to heatsink	0.35		K/W	Mounting surface, smooth, flat and greased	
T	Mounting torque		to nut	to device	Lubricated threads (Non-lubricated threads)	
			20(27.5)	25		lbf-in
			0.23(0.32)	0.29		kgf.m
			2.3(3.1)	2.8		Nm
wt	Approximate weight	14 (0.49)		g (oz)	See Outline Table	
	Case style	TO-65				

ΔR_{thJC} Conduction

(The following table shows the increment of thermal resistance R_{thJC} when devices operate at different conduction angles than DC)

Conduction angle	Sinusoidal conduction	Rectangular conduction	Units	Conditions
180°	0.17	0.13	K/W	$T_J = T_J \text{ max.}$
120°	0.21	0.22		
90°	0.27	0.30		
60°	0.40	0.42		
30°	0.69	0.70		

PERFORMANCE CURVES FIGURE

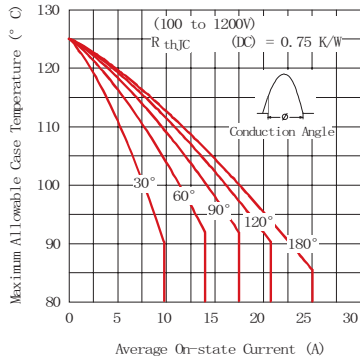

Fig. 1 - Current Ratings Characteristic

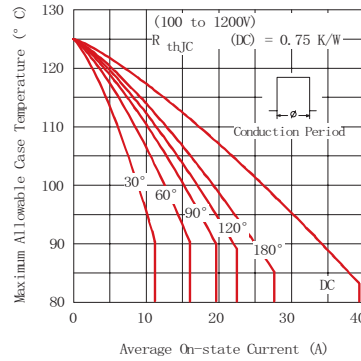

Fig. 2 - Current Ratings Characteristic

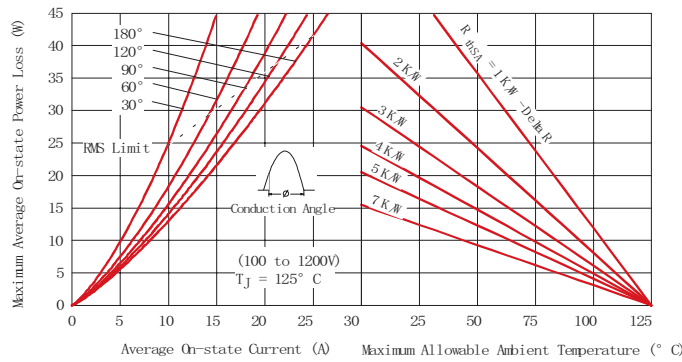

Fig. 3 - On-state Power Loss Characteristics

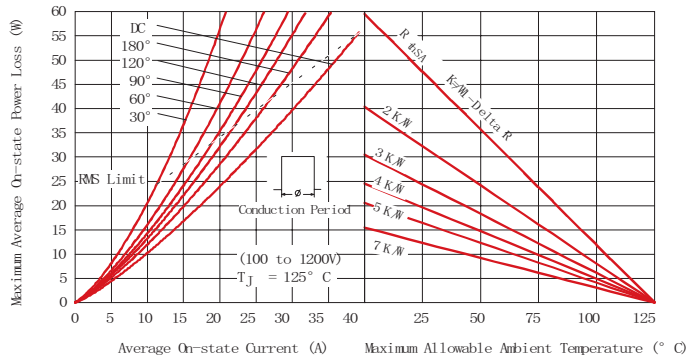

Fig. 4 - On-state Power Loss Characteristics

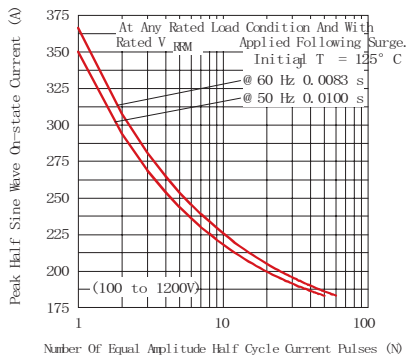

Fig. 5 - Maximum Non-Repitative Surge Current

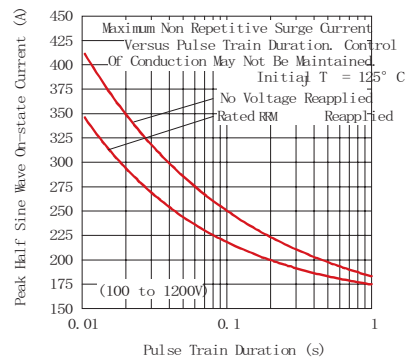

Fig. 6 - Maximum Non-Repitative Surge Current

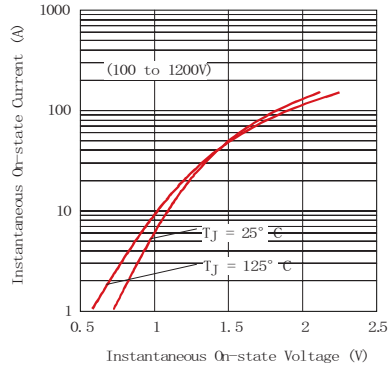

Fig. 7 - Forward Voltage Drop Characteristics

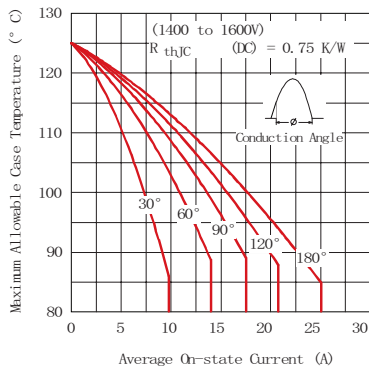

Fig. 8 - Current Ratings Characteristics

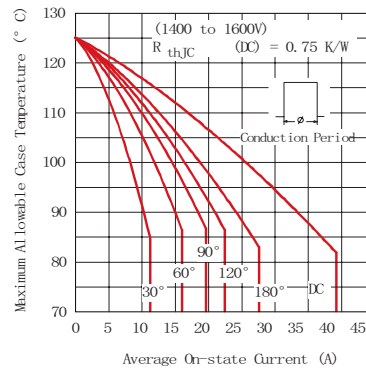

Fig. 9 - Current Ratings Characteristics

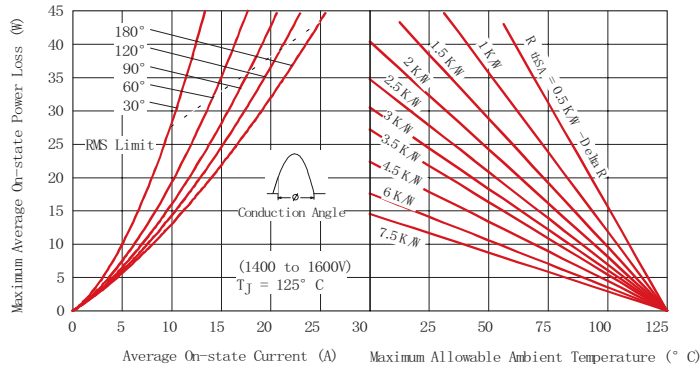

Fig. 10 - On-state Power Loss Characteristics

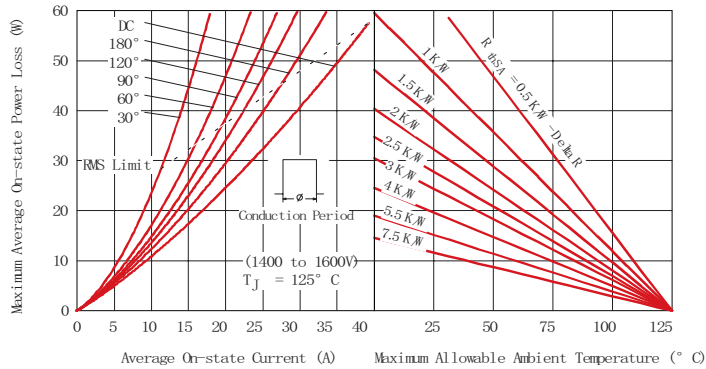

Fig. 11 - On-state Power Loss Characteristics

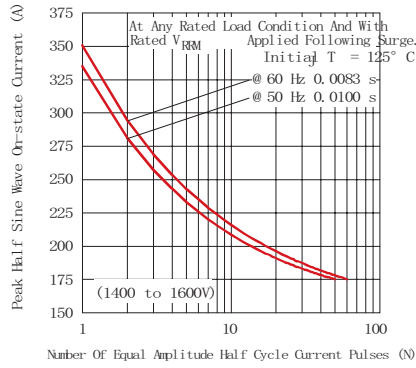

Fig. 12 - Maximum Non-Repetitive Surge Current

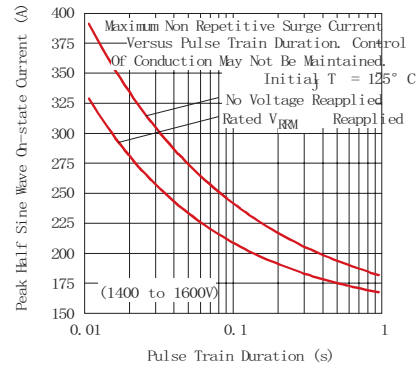

Fig. 13 - Maximum Non-Repetitive Surge Current

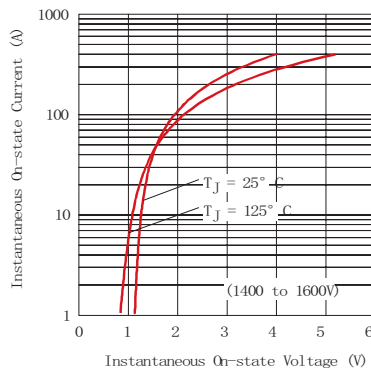

Fig. 14 - Forward Voltage Drop Characteristics

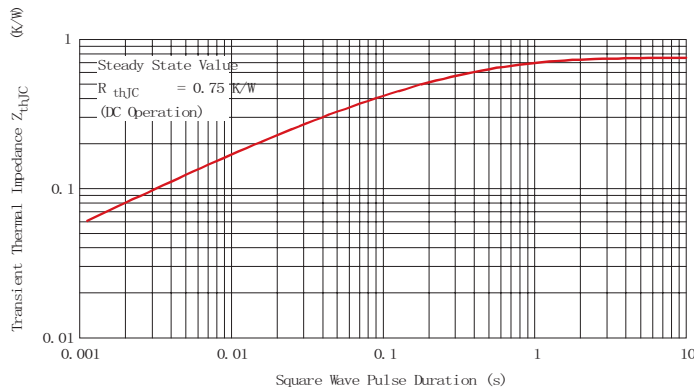

Fig. 15 - Thermal Impedance Z_{thJC} Characteristics

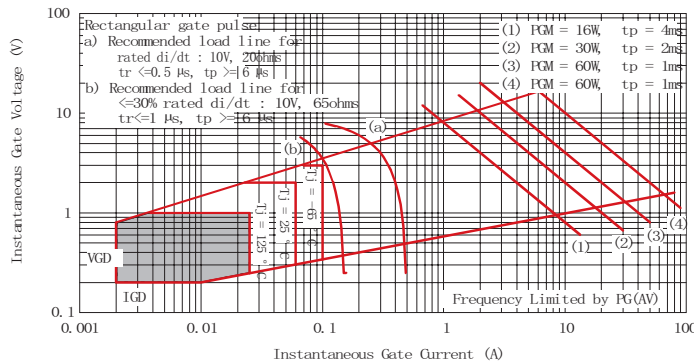
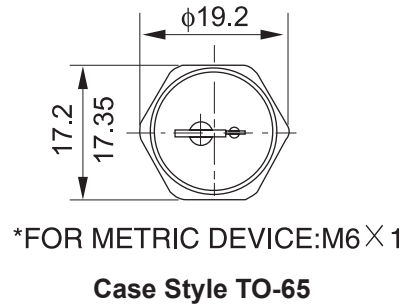
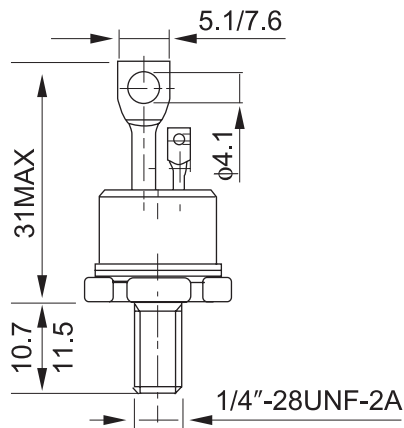

Fig. 16 - Gate Characteristics

OUTLINE



YUEQING LIUJING RECTIFIER CO., LTD

Sale Department: Liujing Building, Yueqing City,
Zhejiang Province

Add: Wanao Industrial Zone, Yueqing city,
Zhejiang Province

Tel: 0086-577-62519692 0089-577-62519693

Fax: 0086-577-62518692

International Export: 0086-577-62571902

Technical Support: 0086-15868768965

After Service: 400-6606-086

<http://www.china-liujing.com>

<http://www.liujingdianqi.cn>

<http://www.cnrectifier.com>

<http://www.cnthyristor.com.cn>

MSN: thristors@hotmail.com

打造最具竞争力的电力半导体产品

To be the most competitive Power Semiconductor
Devices manufactory.

LIUJING reserves the right to change limits, test conditions and dimensions.

윤정은 이 칼타로그 중에 데이트, 테스트 조건, 외형사이즈에 대한 최종 해석권을 가지고 있습니다.